

This drawing is property of Cox Geelen and may not be copied in whole or in part without the prior written consent of the owner

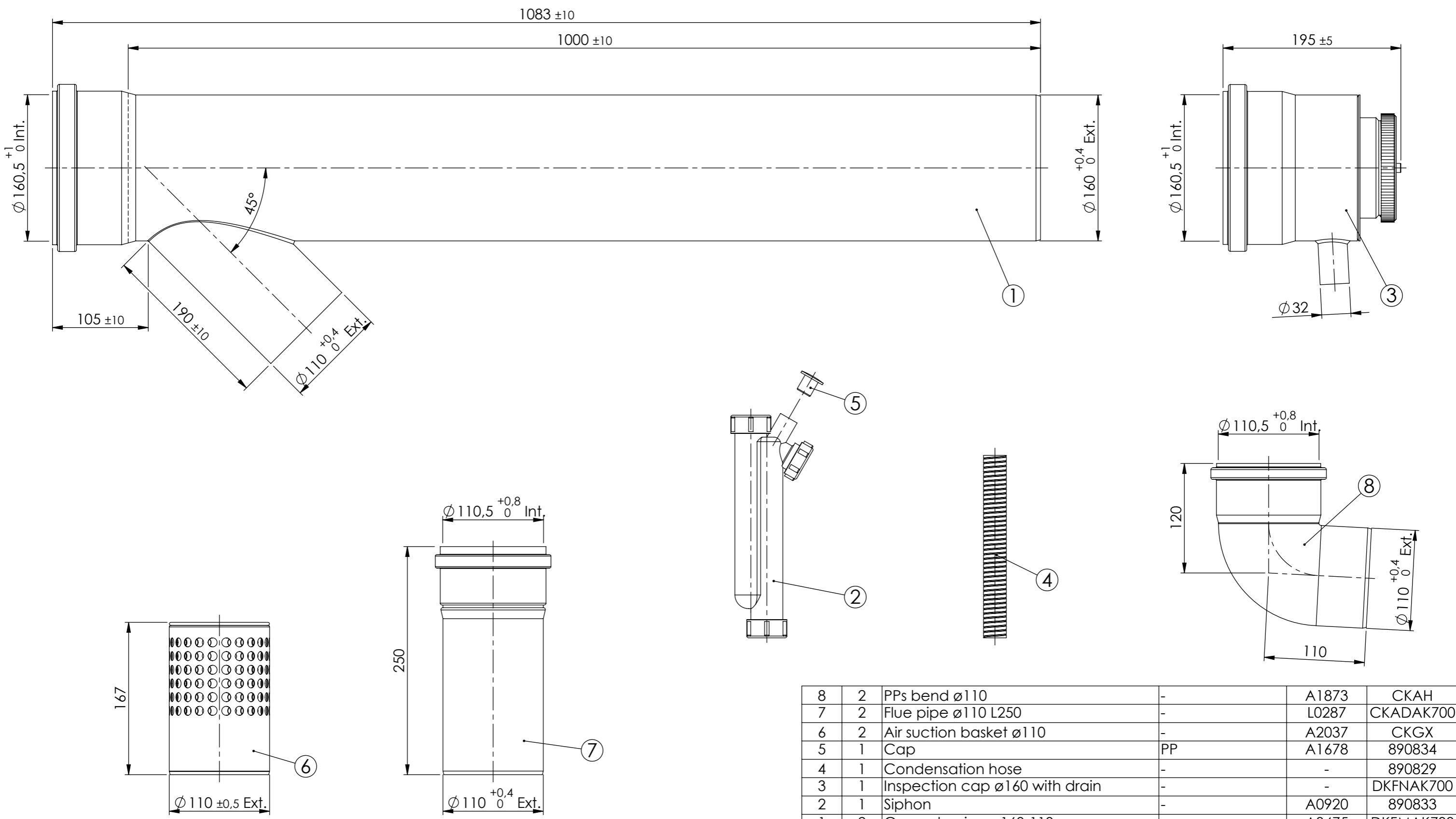

Pos.	QTY.	Description	Material	Drawing	Part nr
8	2	PPs bend ø110	-	A1873	CKAH
7	2	Flue pipe ø110 L250	-	L0287	CKADAK700
6	2	Air suction basket ø110	-	A2037	CKGX
5	1	Cap	PP	A1678	890834
4	1	Condensation hose	-	-	890829
3	1	Inspection cap ø160 with drain	-	-	DKFNAK700
2	1	Siphon	-	A0920	890833
1	2	Cascade pipe ø160-110	-	A3475	DKFMAK700

Scale: 1:4      Unit of measure: mm      Material: -      Comments:

Title: Cascade starter set ø160-110

CAD Model: Cascade starter set 160 DKLL  
Configuration: Standard

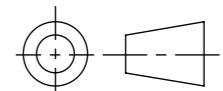
 <b>Cox Geelen</b> www.coxgeelen.com	Tolerances: ø = ±0,5 L = ±3 < = ±3°	Projection: 	Dwg. no. : <b>A3055 P00</b>   A3
	00   Production drawing   15001   06-10-2015   D. Hendrix   E. Franssen Revisions   Created   Checked		