

This drawing is property of Cox Geelen and may not be copied in whole or in part without the prior written consent of the owner

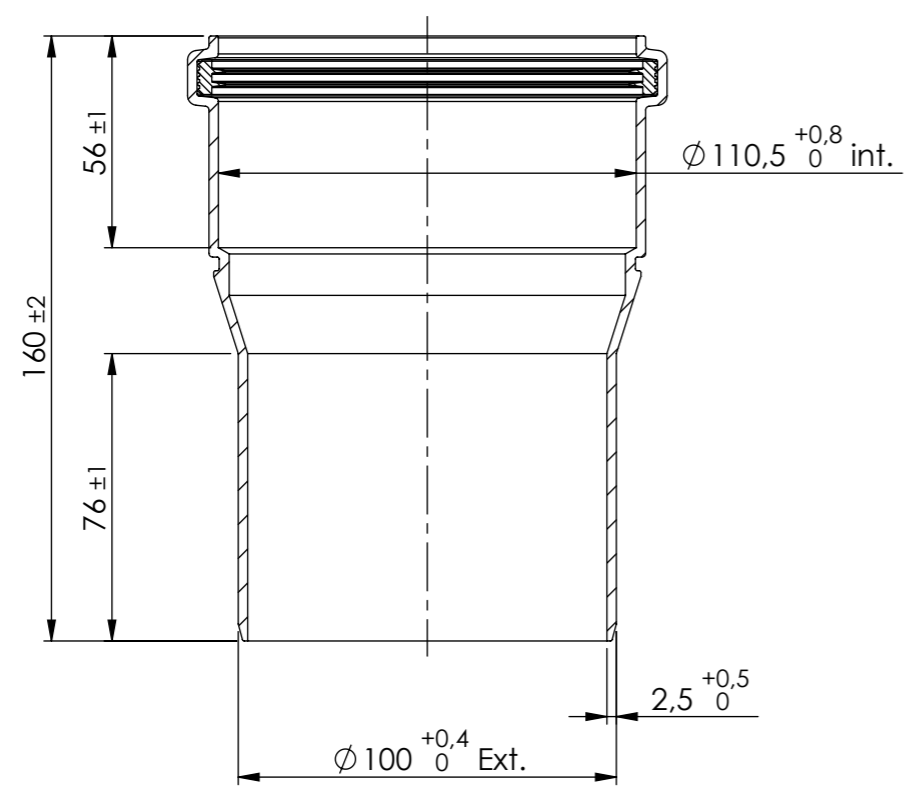

SECTION A-A

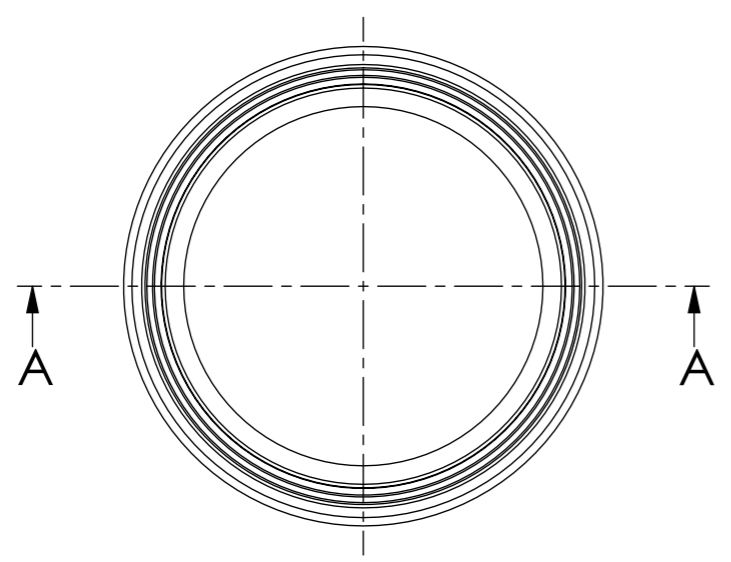
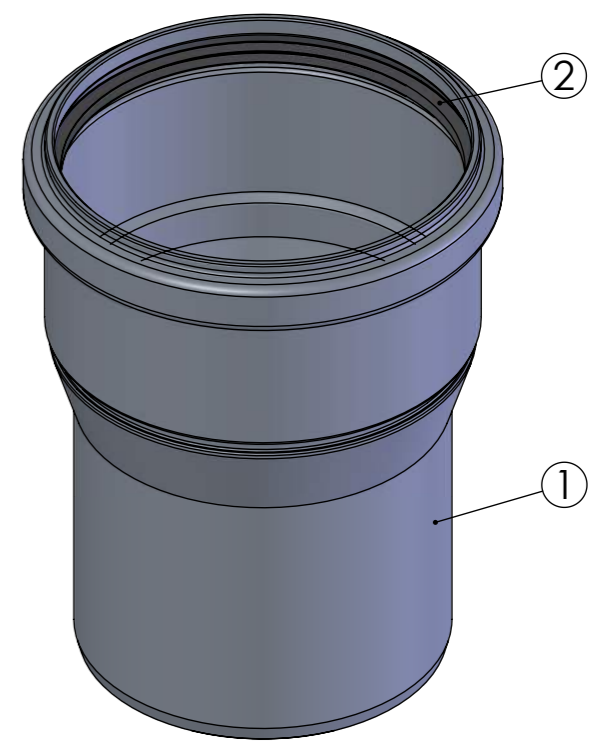

Pos.	QTY.	Description	Material	Drawing	Part nr
2	1	Seal ø110	EPDM Flue gas	L0295	891198
1	1	Expansion ø110-100 L160	PPs	-	-

Scale: 1:2 Unit of measure: mm Material: - Comments:

Title: Expansion ø100-110 L160 Old drawing: L0351

CAD Model: PPs verloop 100-110 Configuration: Default

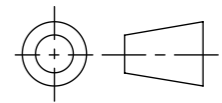
 Cox Geelen www.coxgeelen.com	Tolerances: $\varnothing = \pm 0,5$ $L = \pm 3$ $< = \pm 3^\circ$	Projection: 	Dwg. no. : A0779 P00 A3
	00 Production drawing 12002 11-04-2012 R. Houwen C. Vaessen Revisions Created Checked		